



Description

Solenoids JAKŠA TMEx35/A/B/C/D and TMEx40/A/B/C/D are built in explosion protection “increased safety” and “encapsulation” and are intended for use as actuators with JAKŠA solenoid valves.

These solenoids can be used in hazardous areas zone 1 and 2 (presence of explosive gas, vapour and mist).



Mark of protection: II 2G Ex eb mb IIC T4/T5 Gb

Approval number: SIQ 10 ATEX 183X
Issued by: Slovenski inštitut za kakovost in meroslovje (SIQ),
Mašera – Spasičeva ulica 10, 1000 Ljubljana, Slovenia

Technical data:

<i>Type of explosion protection:</i>	Encapsulation + Increased safety
<i>Conformity with standards:</i>	Directive 2014/34/EU (ATEX) SIST EN 60079-0:2018 SIST EN 60079-7:2015 SIST EN 60079-18:2015
<i>Materials:</i>	Housing and cover of antistatic thermoplastic material, coil, rectifier and fuse encapsulated in epoxy resin
<i>Electrical connection:</i>	Built-in terminal Ex e I/II
<i>Cable gland:</i>	Ø 7 – 13 mm II 2G Ex e II IP68 (M20x1.5)
<i>Grounding:</i>	Inner and outer grounding bolts galvanically binded to metallic part of solenoid
<i>Coil wire insulation class:</i>	H 180°C
<i>Protection of enclosure:</i>	IP54 (IEC 529)
<i>Fuse:</i>	Thermal fuse 115°C, 3 A + cartridge fuse 1 A
<i>Duty cycle:</i>	S1 (continuous, ED 100%)

Ordering information:

Order code	Type	Voltage	Power	Maximum ambient, equipment or media temperature T_{max}	
				Class T5	Class T4
290100	TMEx35/D	AC 230 V / DC 200 V \pm 10%	10 W	+45°C	+70°C
290106	TMEx35/C	AC/DC 110 V \pm 10%	10 W	+45°C	+65°C
290102	TMEx35/B	AC/DC 48 V \pm 10%	10 W	+55°C	+75°C
290103	TMEx35/A	AC/DC 24 V \pm 10%	10 W	+45°C	+65°C
290107	TMEx35	DC 12 V \pm 10%	8 W	+49°C	+69°C
290110	TMEx40/D	AC 230 V / DC 200 V \pm 10%	15 W	+40°C	+65°C
290116	TMEx40/C	AC/DC 110 V \pm 10%	15 W	+45°C	+70°C
290112	TMEx40/B	AC/DC 48 V \pm 10%	15 W	+50°C	+75°C
290113	TMEx40/A	AC/DC 24 V \pm 10%	15 W	+50°C	+70°C

Minimum ambient temperature: -40°C

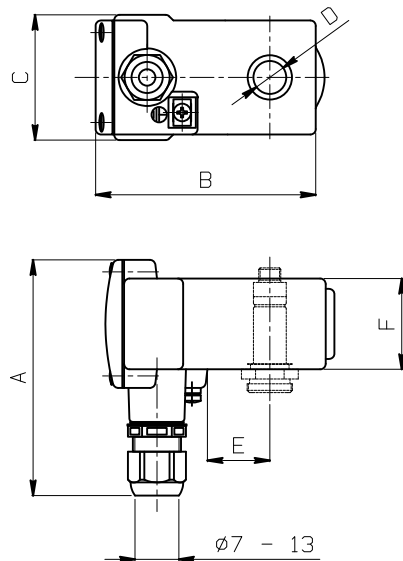

Dimensions [mm] and mass [kg]:

Type	A	B	C	D	E	F	Mass
TMEx35	102	105	57	15	28.5	42	0.5
TMEx40	126	110	71	24	33	66	0.95

INSTALLATION INSTRUCTION**WARNING: Installation should be performed by qualified personnel only!**

Intrusion of damp into the coil drastically shortens the coil life, so adhere strictly to this instruction to prevent the damage!

Before installing make sure that the solenoid is not mechanically damaged.

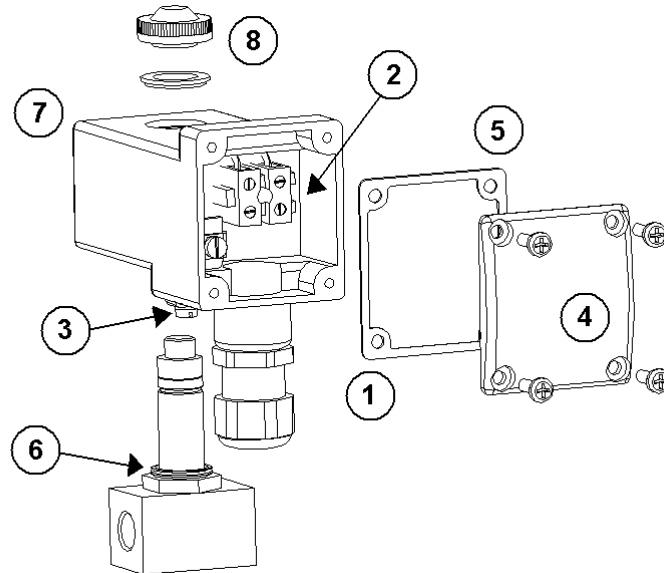
**a) Cable feed and wiring**

Feed the cable through the cable gland (1) in the way that prevents damp accumulation near the cable gland and possible intrusion into the terminal box (2).

NOTE: TMEx40 coil cannot be mounted onto valve in downward position (as shown above). Additional suitable protection from damp intrusion should be provided if necessary.

Connect the wires (cross-section between 0.5 and 2.5 mm²) to the corresponding terminals. Strip 5 to 7 mm of insulation at wire ends. Tighten screws with torque of 0.4 Nm. Additional grounding is possible by means of external ground terminal (3).

Cable gland nut (1) should be tightened with a torque not exceeding 1.0 Nm. Perform the strength check: the cable must not be pulled out of the cable gland.

Place the flat gasket (5) into the groove on the cover (4), then fix the cover with four M4 screws and tighten them with the torque of 0.4 - 0.6 Nm, so that the flat gasket prevents damp or dust intrusion into the terminal box.

b) Mounting the solenoid onto solenoid valve

Make sure that both rubber seals (6 and 7) are properly placed, then tighten the nut (8) manually, with the torque of 1.0 - 1.5 Nm, to prevent the damp intrusion into the winding.

RECOMMENDATION: If a solenoid valve operates outdoors, an additional protection from rain or snow should be provided.

MAINTENANCE

No solenoid maintenance is required. In case of valve repair follow the installation instructions overleaf when re-installing or re-wiring the solenoid.

Refer to JAKŠA SOLENOID VALVES INSTALLATION AND MAINTENANCE INSTRUCTION for information regarding solenoid valve installation.

WARNING: Before any valve or solenoid repair make sure that the power is switched off!

WARRANTY

Each solenoid incorporates a rectifier and a pair of fuses. If a voltage peak occurs in the electric circuit, the fuses can burn out and they cannot be replaced. Sources of voltage peaks should therefore be detected and adequate suppression provided in advance to prevent the damage to the solenoid.

NOTE: In case of solenoid malfunction caused by unsuppressed voltage peaks or mechanical damage caused by improper handling, the warranty is void!

SPECIAL CONDITIONS OF USE

- Solenoid must be electrically protected in the way that prevents short-circuit current from exceeding 1500 A.
- Solenoid must not be exposed to external mechanical strain during course of operation. If there is a possibility of such strain occurring, additional mechanical protection must be provided.
- Use with IIC group: prevent static electrical charging of solenoid housing; always clean solenoid with **damp cloth!**
- Prevent formation of explosive mixture inside the valve.