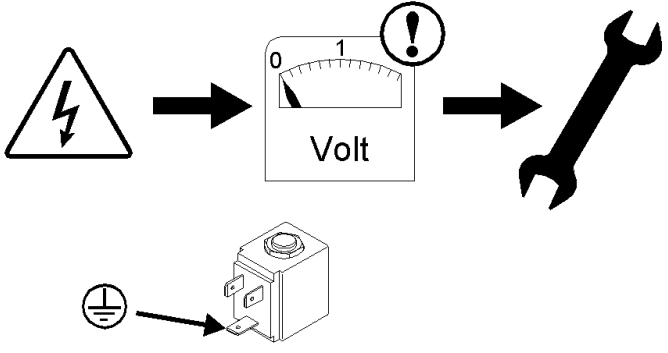
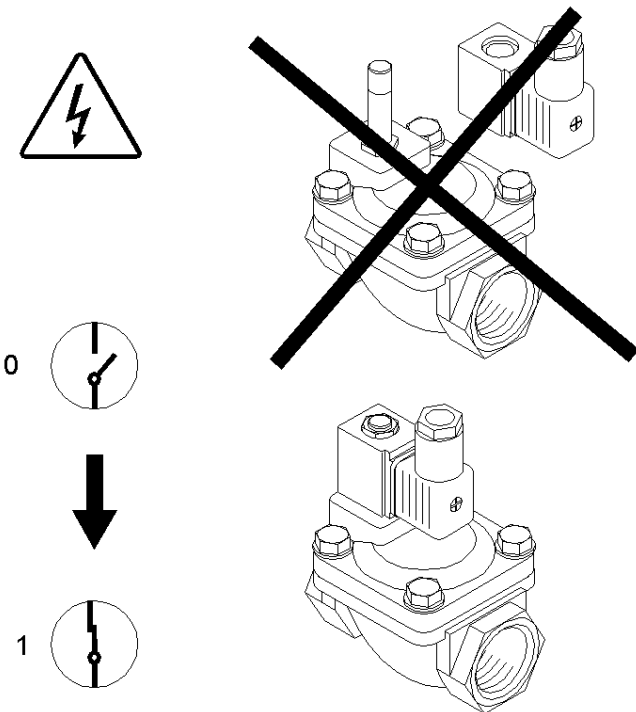
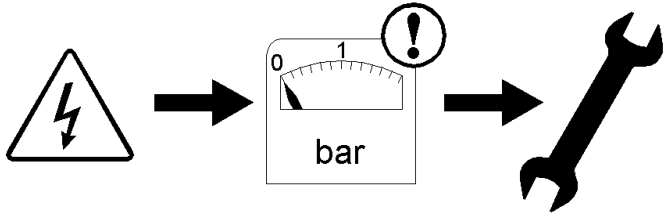

VARNOST	SAFETY
<p><b>PRIMERNA UPORABA</b></p> <p>Le ob upoštevanju teh navodil bo izdelek deloval brezhibno in dolgo služil svojemu namenu. V primeru neupoštevanja navodil ali neprimerne ravnanja z izdelkom prenehajo vse obveznosti proizvajalca. Prav tako preneha garancija za izdelek in pribor. Izdelek služi izključno za medij, ki je naveden v tehničnih podatkih. Uporaba v pogojih, ki niso navedeni v tehničnih podatkih ali v nasprotju s temi navodili, velja za NEPRIMERNO. Za škodo, ki nastane zaradi neprimerne uporabe, proizvajalec ne odgovarja. Tveganje nosi uporabnik sam.</p>	<p><b>PROPER USAGE</b></p> <p>To ensure safe and enduring use of this product you must comply strictly with the instructions inclosed herein. Noncompliance with instructions or improper handling of the product will void your warranty. This product is designed for use exclusively with types of fluids stated in its data sheet. Usage of this product in conditions not specified in the product data sheet or contrary to the instructions hereby provided is considered IMPROPER. Manufacturer will not be held liable for any damage resulting from improper usage of the product.</p>
<p><b>OPOZORILO!</b></p> <ul style="list-style-type: none"> <li>• Pri načrtovanju, vgradnji in uporabi tega izdelka upoštevajte ustrezne veljavne varnostne in tehnične predpise.</li> <li>• Z ustreznimi ukrepi zagotovite, da ni mogoče nenamerno aktiviranje ali poškodba izdelka.</li> <li>• Ventilov ali priključkov v sistemu ne odvijajte ali razstavljajte dokler so pod tlakom. Pred posegom v sistem vedno izklopite električno napetost.</li> <li>• Pazite, da bo gumijasto tesnilo med tuljavo in priključnico pravilno nameščeno.</li> </ul> <p><b>NEVARNOST!</b></p> <p>Nevarnost poškodbe! Med delovanjem se lahko tuljava zelo segreje, zato je ne prijemajte z roko!</p>	<p><b>ATTENTION!</b></p> <ul style="list-style-type: none"> <li>• Observe valid and generally accepted safety rules when planning, installing and using this product.</li> <li>• Take proper measures to prevent unintended operation of the product or damage to it.</li> <li>• Do not attempt to disassemble any valves or lines in the system while they are under pressure. Always turn off the voltage supply before working on the system.</li> <li>• When attaching the plug socket to the coil make sure that the seal is properly fitted.</li> </ul> <p><b>WARNING!</b></p> <p>Risk of injury! Do not touch the coil during operation as it may become very hot!</p>
<p><b>VARNOST • SAFETY</b></p>	

<p><b>1.</b> Pred vgradnjo izklopite napetost! <i>Switch off the voltage before installation!</i></p> 	<p><b>3.</b> Pred vklopom mora biti tuljava pravilno nameščena na ventili! <i>Before switching on power supply make sure that coil is properly fitted onto valve!</i></p> 
<p><b>2.</b> Pred vgradnjo razbremenite tlak v sistemu! <i>Depressurise the system before installation!</i></p> 	

## MONTAŽA • INSTALLATION

**1.**

Montaža tuljave in priključnice  
*Coil and plug socket assembly*

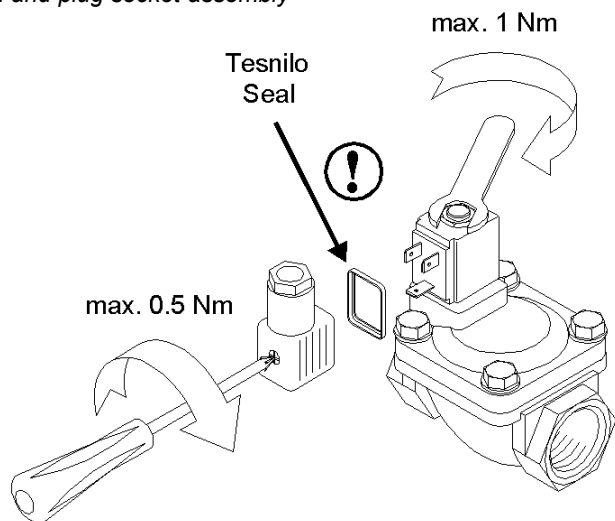

**2.**

Pred namestitvijo ventila očistite cevovod!  
*Clean pipeline before installing the valve!*

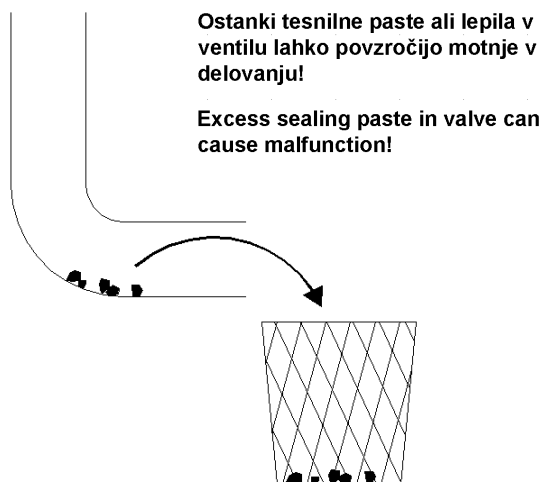

**3.**

Lovilec nečistoč in zatesnitev cevne spoja  
*Dirt trap and pipe connection sealing*

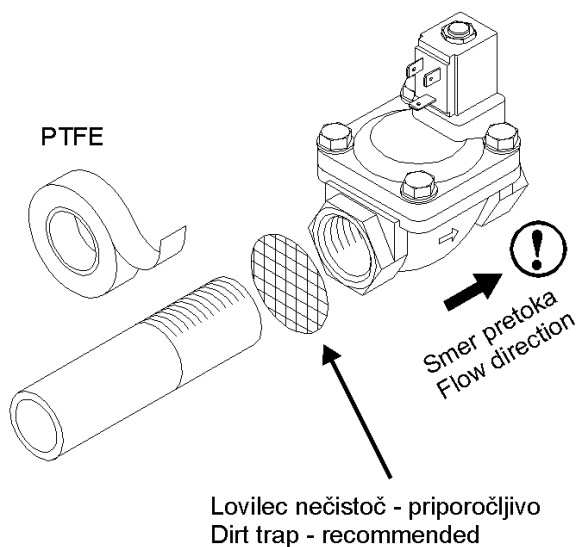

**4.**

Pri privijanju na cevovod uporabite ustrezno orodje!  
*Use proper tools for pipe connection!*

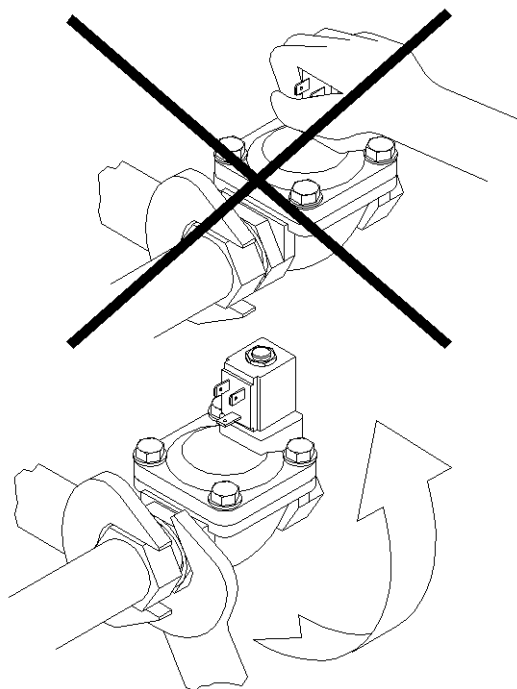

## ODPRAVA MOTENJ V DELOVANJU • TROUBLESHOOTING

**1.**

Preverite napajalno napetost!  
*Check supply voltage!*

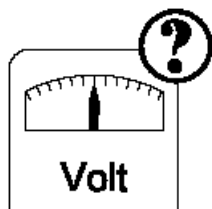

**2.**

Preverite tlak v cevovodu!  
*Check line pressure!*

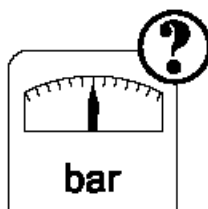

**3.**

Preverite cevovod!  
*Check pipeline!*

